

VALV-TROL LOW FLOW 2-WAY AND 3-WAY VALVES

FOR WATER, 95/5, OIL OR OTHER LIQUIDS

The **Valv-Trol Series of Low Flow Valves** is intended for general industrial use where lower flow rates under 25 GPM (95 LPM) are expected and remote operation is desired. Their rugged steel diaphragm tops, corrosion-resistant bodies, and hardened stainless steel trim make them ideally suited for water or oil hydraulic systems.

Pressure can be piped into any port but because of their semi-balanced design, shifting in one flow direction may be smoother than in the other. (Please consult factory.)

The compression style packing is easily adjusted.
Suitable for a wide range of fluids and temperatures.

Unique skirted valve disc.

Helps gradually start and stop the flow of fluid during shifting.

Replacement seats and discs made of hardened stainless steel.

Proven to be very resistant to the effects of corrosion, wear, and wire drawing for longer service life.

Maintenance is simplified.

Can be fully serviced without removal from the line.

35 PSI (2.4 Bar) air recommended on diaphragm



Model	Type	Port Size (NPT)	PSI*	Cv	Construction *		
					Body	Replaceable Trim	Seals
C-0010	2-Way N.O.	1/2" or 3/4"	3500 (240 Bar)	1.45	Bronze	Hardened S.S.	TFE/Fiber
C-0008	2-Way N.C.	1/2" or 3/4"	3500 (240 Bar)	1.45	Bronze	Hardened S.S.	TFE/Fiber
C-0001	3-Way	1/2" or 3/4"	3500 (240 Bar)	1.45-1.70	Bronze	Hardened S.S.	TFE/Fiber

*Consult factory for special requirements.

The Valv-Trol Advantage

Many parts of Valv-Trol Valves are interchangeable between different models. This helps you to reduce your spare parts inventory and allows us to maintain a more complete inventory for emergency availability and shorter lead times.

Our valves are all subjected to 100% pressure testing to ensure a drop tight seal before we ship to our customers.

THE VALV-TROL COMPANY • 1340 COMMERCE DRIVE • STOW, OHIO 44224
Phone: 800-497-2136 • Fax: (330) 686-2820 • E-mail: sales@valv-trol.com • www.valv-trol.com

MODEL C-0010

3500 PSI (240 Bar) LOW FLOW NORMALLY OPEN 2-WAY

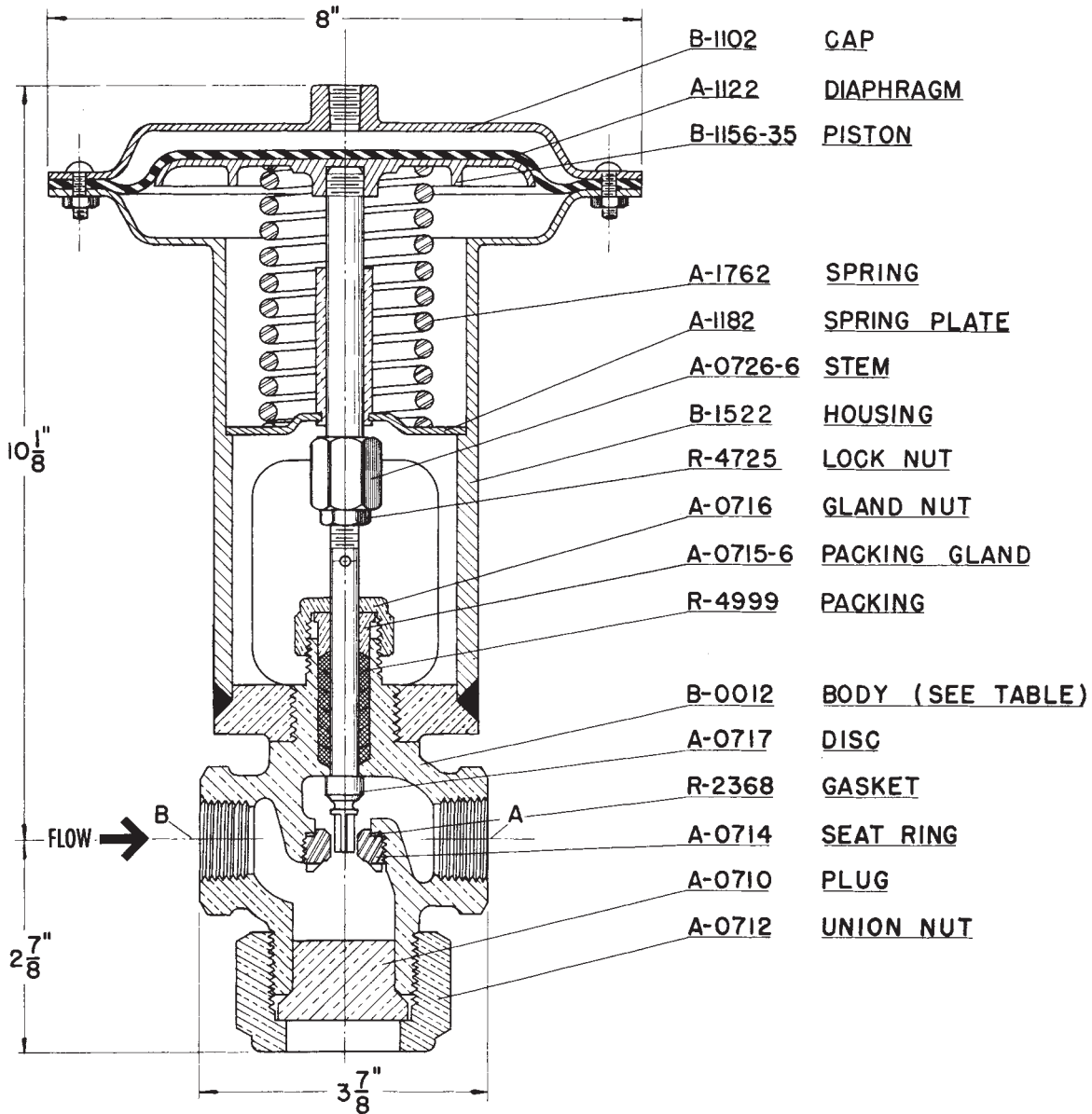

PORT SIZE (NPT)		BODY NUMBER
A	B	
1/2"	1/2"	B-0012-1
3/4"	3/4"	B-0012-3

THE VALV-TROL CO., STOW, OHIO

MODEL C-0008

3500 PSI (240 Bar) LOW FLOW NORMALLY CLOSED 2-WAY

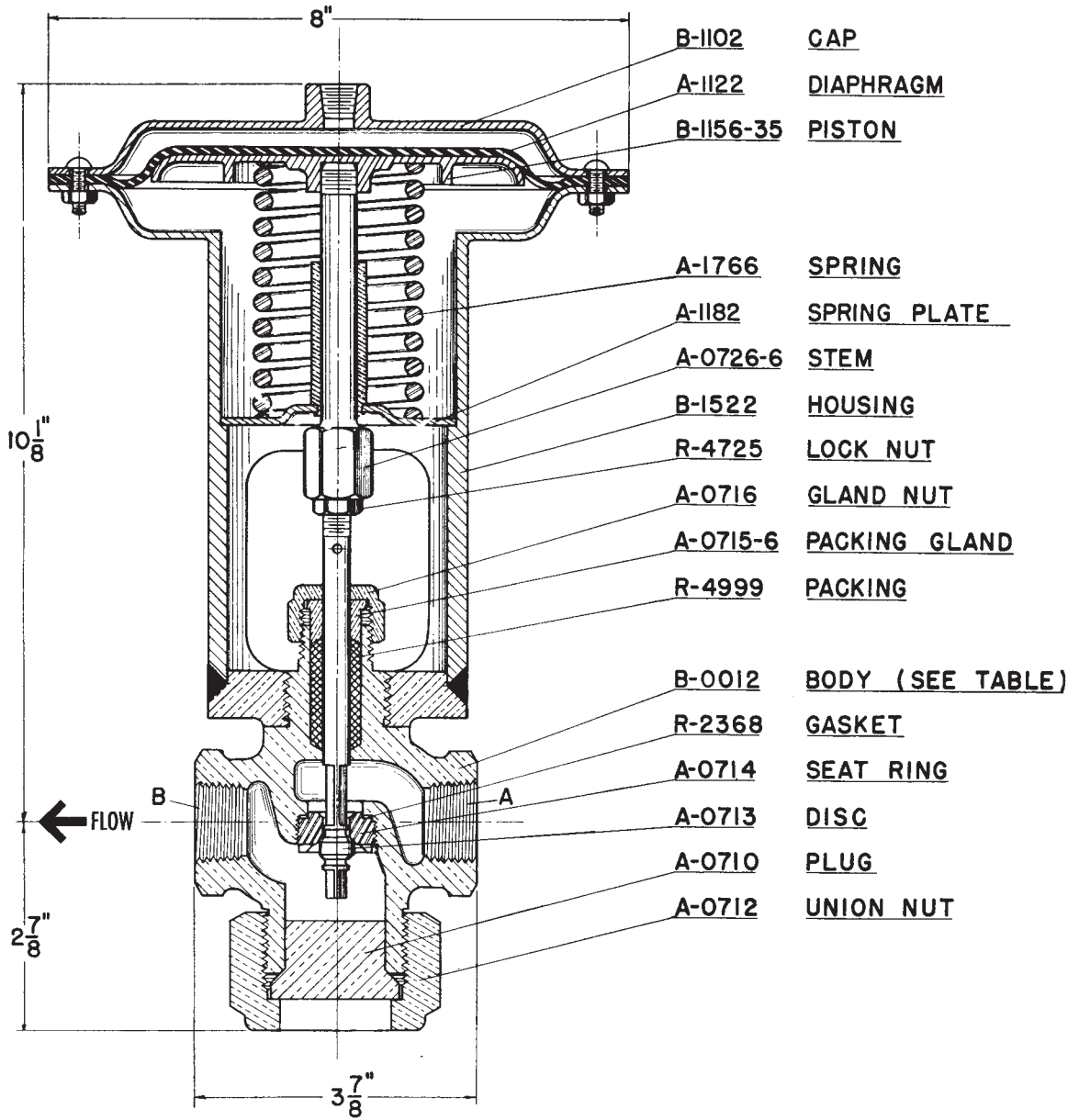

PORT SIZE (NPT)		BODY NUMBER
A	B	
1/2"	1/2"	B-0012-1
3/4"	3/4"	B-0012-3

THE VALV-TROL CO., STOW, OHIO

MODEL C-0001

3500 PSI (240 Bar) LOW FLOW 3-WAY

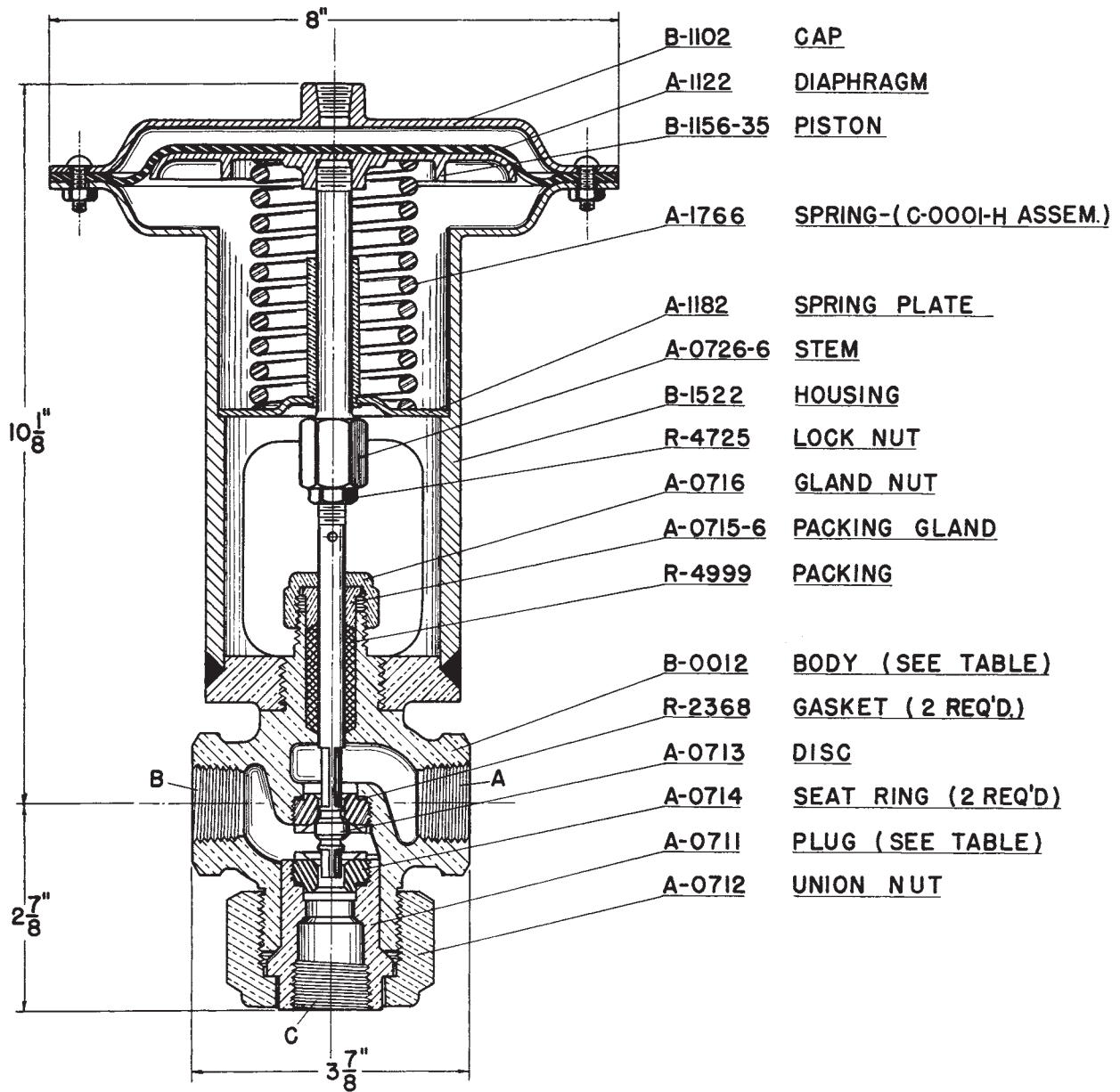

PORT SIZE (NPT)		BODY NUMBER
A	B	
1/2"	1/2"	B-0012-1
3/4"	3/4"	B-0012-3

BOTTOM PORT SIZE (NPT)	PLUG NUMBER
1/2"	A-0711-1