

VALV-TROL 4" NORMALLY OPEN BALANCED 2-WAY/2-POSITION VALVE

FOR WATER, 95/5, OIL OR OTHER LIQUIDS

The **Valv-Trol 4" Normally Open Balanced 2-Way Valve** (Model D-1022) is our 4" Balanced 2-Way Valve in its normally open configuration. (See Bulletin A-30 for 4" Normally Closed version.) This valve is similar to our smaller Balanced 2-Way Valve (see Bulletin A-5), but comes standard with a steel body. This gives us great flexibility in designing the valve to meet your exact requirements.

35 PSI (2.4 Bar) air recommended on diaphragm

Standard model has 4-bolt socket weld flanges.

Compact to save money, as well as space, since extra companion flanges are not needed. Other flanges available..

Other versions of this valve carry conservative ratings up to 6,000 PSI (415 Bar).

Maintenance is simplified.

Can be fully serviced without removal from the line.

Port Model	Max. Size	PSI *	Cv	Construction *		
				Body	Replaceable Trim	Seals
D-1022-S	4" Flanged	3,500 (240 Bar)	153.0	Steel	Hardened S.S.	Buna N

*Consult factory for special requirements.

The Valv-Trol Advantage

Many parts of Valv-Trol Valves are interchangeable between the same size 2-way, 3-way, and check valves. This helps you to reduce your spare parts inventory and allows us to maintain a more complete inventory for emergency availability and shorter lead times.

Our valves are all subjected to 100% pressure testing to ensure a drop tight seal before we ship to our customers.

THE VALV-TROL COMPANY • 1340 COMMERCE DRIVE • STOW, OHIO 44224
Phone: 800-497-2136 • Fax: (330) 686-2820 • E-mail: sales@valv-trol.com • www.valv-trol.com

© 2011 The Valv-Trol Company, all rights reserved

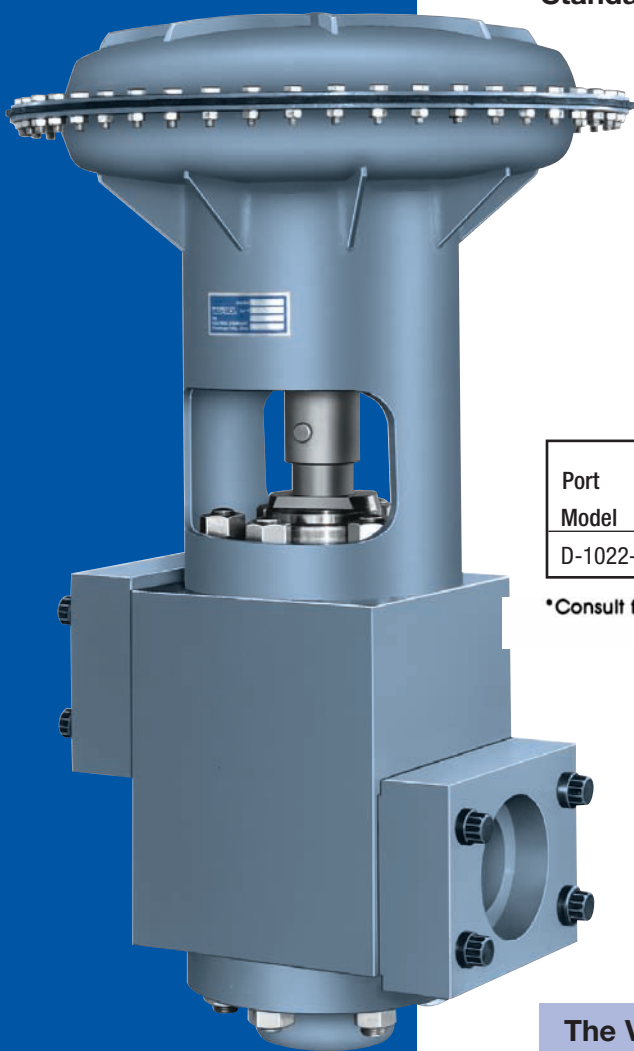

MODEL D-1022-S

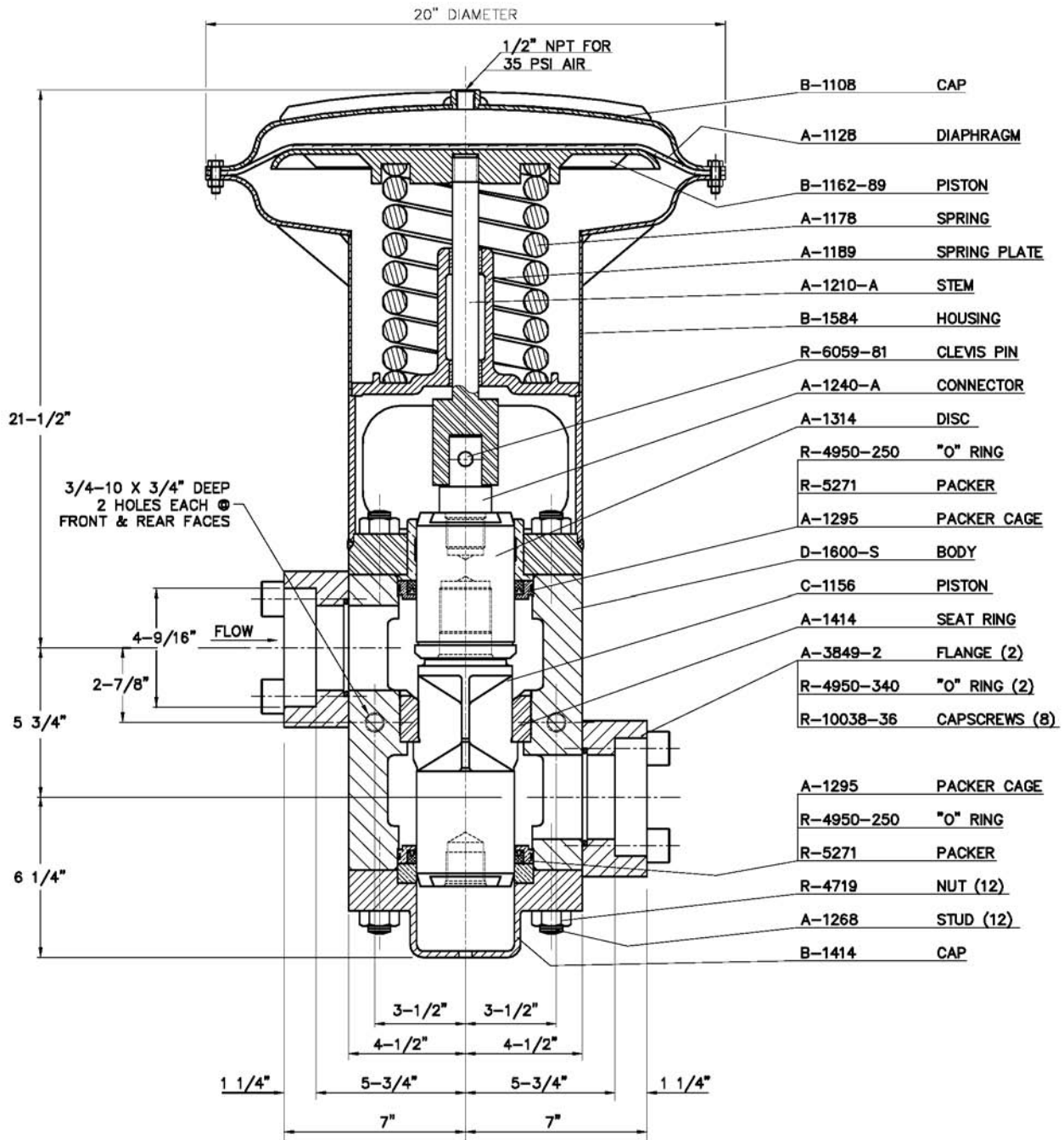

VALVE MODEL #D-1022-S SHOWN—MANY OTHER VERSIONS AVAILABLE

THE VALV-TROL CO., STOW, OHIO