

VALV-TROL ANGLE CHECK VALVES

FOR WATER, 95/5, OIL OR OTHER LIQUIDS

The **Valv-Trol Angle Check Valve** is designed for the roughest industrial conditions. Because of its rugged construction, it is capable of handling pressures up to 3,500 PSI (240 Bar) (Higher pressure ratings are available. Please consult factory.) This valve, unlike some competitors' valves, is specifically designed for severe water hydraulic service.

Renewable trim is made of hardened stainless steel

Proven to be very resistant to the effects of corrosion, wear, and wire drawing for longer service life.

Metal-to-metal seating surface is lapped.

Gives drop-tight seal and is 100% pressure checked before shipment.

Spring-loaded design

Will function properly when mounted in any position.

Maintenance is simplified.

Can be fully serviced without removal from the line.



↑
FREE FLOW

Model	Port Size	Inlet Port	Outlet Port	Construction *		
				Max.PSI *	Body	Replaceable Trim
B-1000	3/4"	1/2" or 3/4" NPT	3/4" NPT	3500 (240 Bar)	Bronze	Hardened S.S.
B-1001	1"	3/4" or 1" NPT	1" NPT	3500 (240 Bar)	Bronze	Hardened S.S.
B-1002	1-1/4"	1" or 1-1/4" NPT	1-1/4" NPT	3500 (240 Bar)	Bronze	Hardened S.S.
B-1003	1-1/2"	1-1/4" or 1-1/2" NPT	1-1/2" NPT	3500 (240 Bar)	Bronze	Hardened S.S.
B-1004	2"	1-1/2" or 2" NPT	2" NPT	3500 (240 Bar)	Bronze	Hardened S.S.
B-1005	3"	2-1/2" or 3" NPT	3" NPT	3500 (240 Bar)	Bronze	Hardened S.S.
B-1006	4"	3" or 4" NPT	4" Flanged	3500 (240 Bar)	Steel	Hardened S.S.

Larger Sizes available.

*Consult factory for special requirements.

The Valv-Trol Advantage

Many parts of Valv-Trol Valves are interchangeable between the same size 2-way, 3-way, and check valves. This helps you to reduce your spare parts inventory and allows us to maintain a more complete inventory for emergency availability and shorter lead times.

Our valves are all subjected to 100% pressure testing to ensure a drop tight seal before we ship to our customers.

THE VALV-TROL COMPANY • 1340 COMMERCE DRIVE • STOW, OHIO 44224
Phone: 800-497-2136 • Fax: (330) 686-2820 • E-mail: sales@valv-trol.com • www.valv-trol.com

ANGLE CHECK VALVES

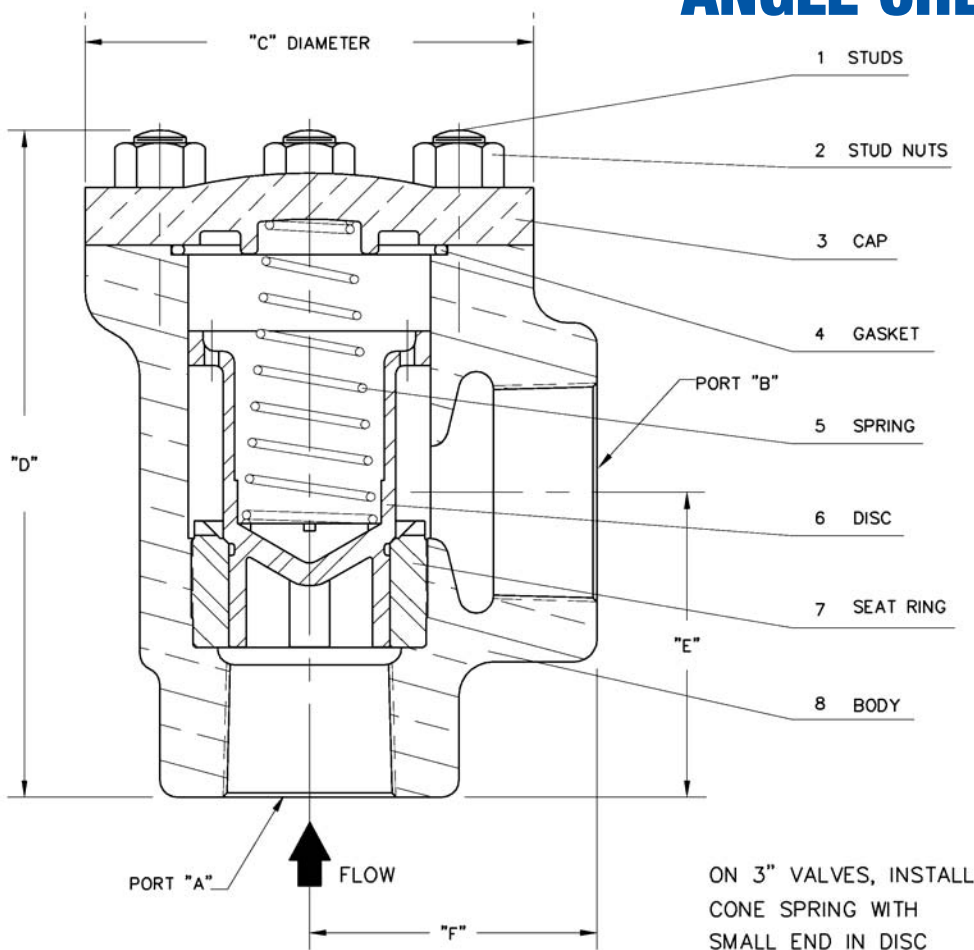

On 3" valves, install cone spring with small end in the disc.

VALVE NUMBER	A	B	C	D	E	F
B-1000	1/2" or 3/4"	3/4"	3"	4-1/2"	2-1/4"	2-1/4"
B-1001	3/4" or 1"	1"	4"	5-1/2"	2-1/2"	2-1/2"
B-1002	1" or 1-1/4"	1-1/4"	4"	5-3/4"	2-5/8"	2-3/4"
B-1003	1-1/4" or 1-1/2"	1-1/2"	4-7/8"	6-1/4"	3"	3"
B-1004	1-1/2" or 2"	2"	4-7/8"	7-3/8"	3-1/4"	3-1/4"
B-1005	2-1/2" or 3"	3"	7"	11"	4-3/4"	4-3/4"
B-1006	3" or 4"	4"	9"	14-5/8"	6-3/4"	8-3/8"

PARTS LIST

Ref.	No.	Valve No.	B-1000	B-1001	B-1002	B-1003	B-1004	B-1005	B-1006
	1	Studs	A-1250	A-1256	A-1256	A-1260	A-1260	A-1264	R-10200
	2	Stud Nuts	R-4713	R-4715	R-4715	R-4716	R-4716	R-4718	- 0 -
	3	Cap	A-1602	A-1606	A-1606	A-1610	A-1610	A-1612	A-1618
	4	Gasket	R-4950-125	R-4950-227	R-4950-227	R-4950-232	R-4950-232	R-4950-243	R-4950-249
	5	Spring	A-1720-A	C-1726-A	C-1726-A	C-1730-A	C-1730-A	C-1732-A	A-1734-A
	6	Disc	A-1320	A-1318	A-1318	A-1322	A-1322	A-1324	A-1395
	7	Seat Ring	A-1402	A-1406	A-1406	A-1410	A-1410	A-1412	A-1414
	8	Body	B-1252	B-1254	B-1256	B-1258	B-1260	D-1314	D-1323
		Flange	- 0 -	- 0 -	- 0 -	- 0 -	- 0 -	- 0 -	A-3836
		Flange O-Ring	- 0 -	- 0 -	- 0 -	- 0 -	- 0 -	- 0 -	R-4950-238