

# VALV-TROL BALANCED 2-WAY/3-POSITION VALVES FOR THROTTLING SERVICE

## FOR WATER, H.W.C.F., OIL OR OTHER LIQUIDS

35 PSI (2.4 Bar) air recommended on diaphragm



The **Valv-Trol 3-Position 2-way Valve** (Throttle Type) is basically our standard Balanced 2-Way Valve (Bulletin A-5) with a double diaphragm top assembly. The lower diaphragm, which is actuated by applying air to port "A", will stroke the valve completely. This operation is the same as a standard 2-way valve.

The upper diaphragm is actuated by applying air to port "B". This will stroke the valve anywhere from 10% to 90% of full stroke depending on the setting of the nuts on the adjusting stem.

With this valve, you have a choice of full flow, restricted flow, or no flow. The selection depends on which diaphragm is actuated. This feature is often used to slow the ram on a hydraulic press just before the press closes completely or when it starts to open.

**A** The intermediate position is determined by the setting of the adjusting nuts on top of the valve.

**Renewable trim made of hardened stainless steel.**

Proven to be very resistant to the effects of corrosion, wear, and wire drawing for longer service life.

Can be field converted from Normally Open (NO) to Normally Closed (NC) or vice versa.

Model	Port Size	Max. PSI*	Cv	Construction *		
				Body	Replaceable Trim	Seals
D-1010-T	3/4"	3500 (240 Bar)	4.2	Bronze	Hardened S.S.	Buna N
D-1011-T	1"	3500 (240 Bar)	12.0	Bronze	Hardened S.S.	Buna N
D-1012-T	1-1/4"	3500 (240 Bar)	13.0	Bronze	Hardened S.S.	Buna N
D-1013-T	1-1/2"	3500 (240 Bar)	19.9	Bronze	Hardened S.S.	Buna N
D-1014-T	2"	3500 (240 Bar)	24.0	Bronze	Hardened S.S.	Buna N
D-1015-T	3"	3500 (240 Bar)	58.0	Bronze	Hardened S.S.	Buna N

\*Consult factory for special requirements.

When ordering, specify if valve is to be assembled normally open (N.O.) or normally closed (N.C.). Double diaphragm assembly may also be added to some 4" valves.

### The Valv-Trol Advantage

Many parts of Valv-Trol Valves are interchangeable between the same size 2-way, 3-way, and check valves. This helps you to reduce your spare parts inventory and allows us to maintain a more complete inventory for emergency availability and shorter lead times.

Our valves are all subjected to 100% pressure testing to ensure a drop tight seal before we ship to our customers.

**THE VALV-TROL COMPANY • 1340 COMMERCE DRIVE • STOW, OHIO 44224**  
Phone: 800-497-2136 • Fax: (330) 686-2820 • E-mail: sales@valv-trol.com • www.valv-trol.com

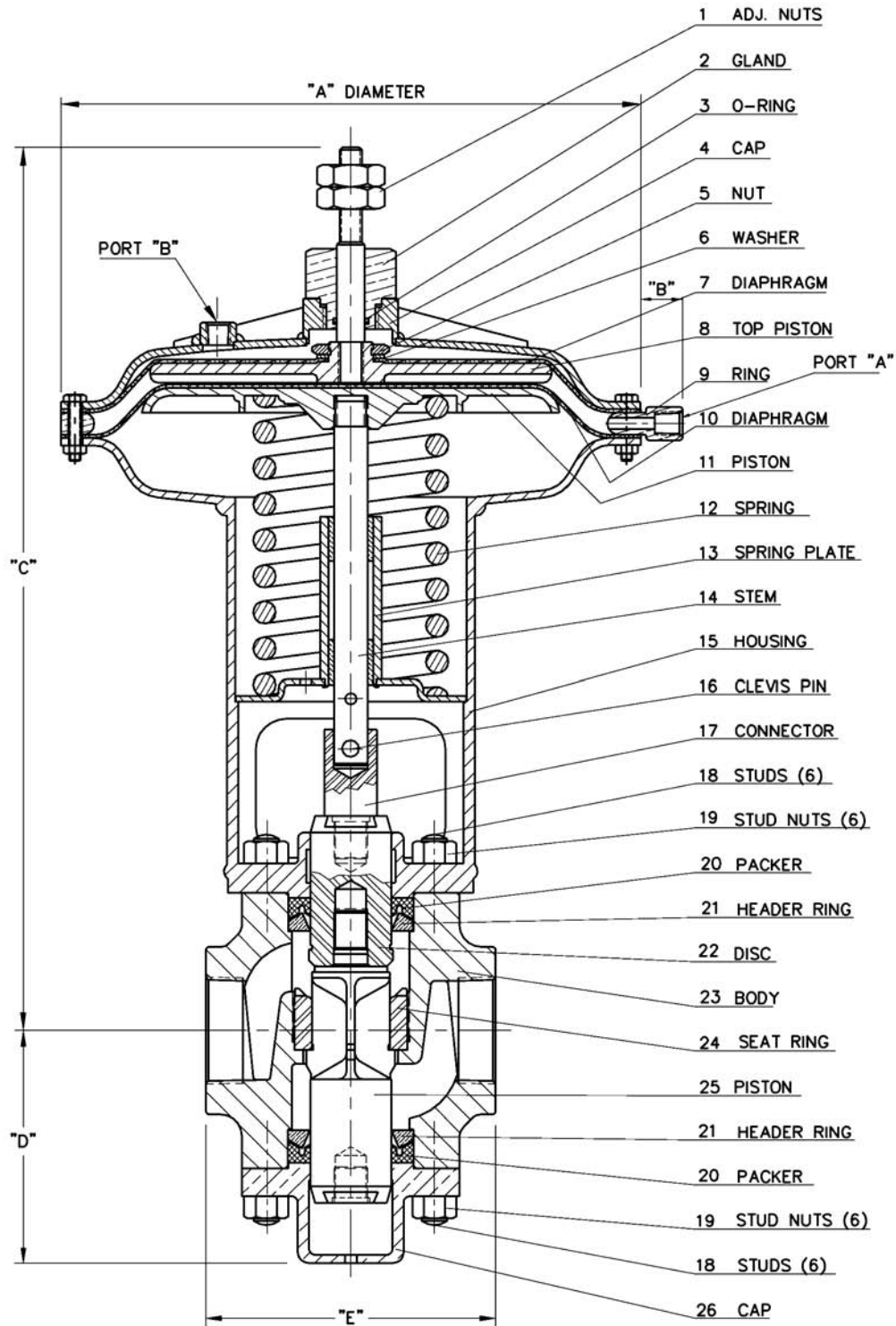

VALVE NUMBER	PIPE SIZE	A	B	C	D	E	AIR CONNECTIONS
D-1010-T	3/4"	8"	15/16"	11 1/16"	2 1/2"	4 1/2"	1/4"
D-1011-T	1"	11"	7/8"	18"	4 5/8"	5 1/4"	1/4"
D-1012-T	1 1/4"	11"	7/8"	18"	4 5/8"	5 1/2"	1/4"
D-1013-T	1 1/2"	13"	1"	20 1/8"	5 1/4"	6 1/2"	1/4"
D-1014-T	2"	13"	1"	20 1/8"	5 1/4"	6 1/2"	1/4"
D-1015-T	3"	20"	1"	28 3/8"	7 1/4"	9 3/4"	1/2"

**NORMALLY OPEN VALVE SHOWN**

Illustration typical of 1"-3" valves.  
See page 4 for 3/4" valve

# BALANCED 2-WAY/3-POSITION VALVE

## 3500 PSI (240 Bar)

### PARTS LIST

Ref. No.	Valve No. / Valve Size	D-1010-T 3/4"	D-1011-T 1"	D-1012-T 1-1/4"	D-1013-T 1-1/2"	D-1014-T 2"	D-1015-T 3"
1	Adjusting Nuts		A-0998	A-0998	A-0998	A-0998	R-4758
2	Gland		A-0999	A-0999	A-0999	A-0999	A-1080
3	O-Ring		R-4950-114	R-4950-114	R-4950-114	R-4950-114	R-4950-220
4	Cap		B-0072	B-0072	B-0064	B-0064	B-0065
5	Nut		A-0992	A-0992	A-0992	A-0992	A-1083
6	Washer		A-0994	A-0994	A-0994	A-0994	A-1084
7	Diaphragm		A-0608	A-0608	A-0996	A-0996	A-1085
8	Top Piston		A-0610	A-0610	A-0990	A-0990	A-1086
9	Ring		A-1105	A-1105	A-1107	A-1107	B-0338
10	Diaphragm		A-1124	A-1124	A-1126	A-1126	A-1128
11	Piston		B-1158-47	B-1158-47	B-1160-57	B-1160-57	B-1162-89
12	Spring		A-1160	A-1160	A-1168	A-1168	A-1178
13	Spring Plate		A-1184	A-1184	A-1186	A-1186	A-1188
14	Top Stem		A-1206	A-1206	A-1208	A-1208	A-1210
15	Housing		B-1544	B-1544	B-1562	B-1562	B-1582
16	Clevis Pin		R-6056-39	R-6056-39	R-6056-41	R-6056-41	R-6057-65
17	Connector		A-1236	A-1236	A-1238	A-1238	A-1240
18	Studs (12 Req.)		A-1256	A-1256	A-1260	A-1260	A-1264
19	Nuts (12 Req.)		R-4715	R-4715	R-4716	R-4716	R-4718
20	Packer		A-3136	A-3136	A-3138	A-3138	A-3140
21	Header Ring		A-1286	A-1286	A-1290	A-1290	A-1293
22	Disc		A-1306	A-1306	A-1310	A-1310	A-1312
23	Body		C-1254	C-1256	C-1258	C-1260	D-1316
24	Seat Ring		A-1406	A-1406	A-1410	A-1410	A-1412
25	Piston		A-1516	A-1516	A-1520	A-1520	C-1152
26	Cap		B-1406	B-1406	B-1410	B-1410	B-1412

SEE PAGE 4

THE VALV-TROL CO., STOW, OHIO

# MODEL D-1010-T

## BALANCED 2-WAY/3-POSITION VALVE

3/4" 3500 PSI (240 Bar)

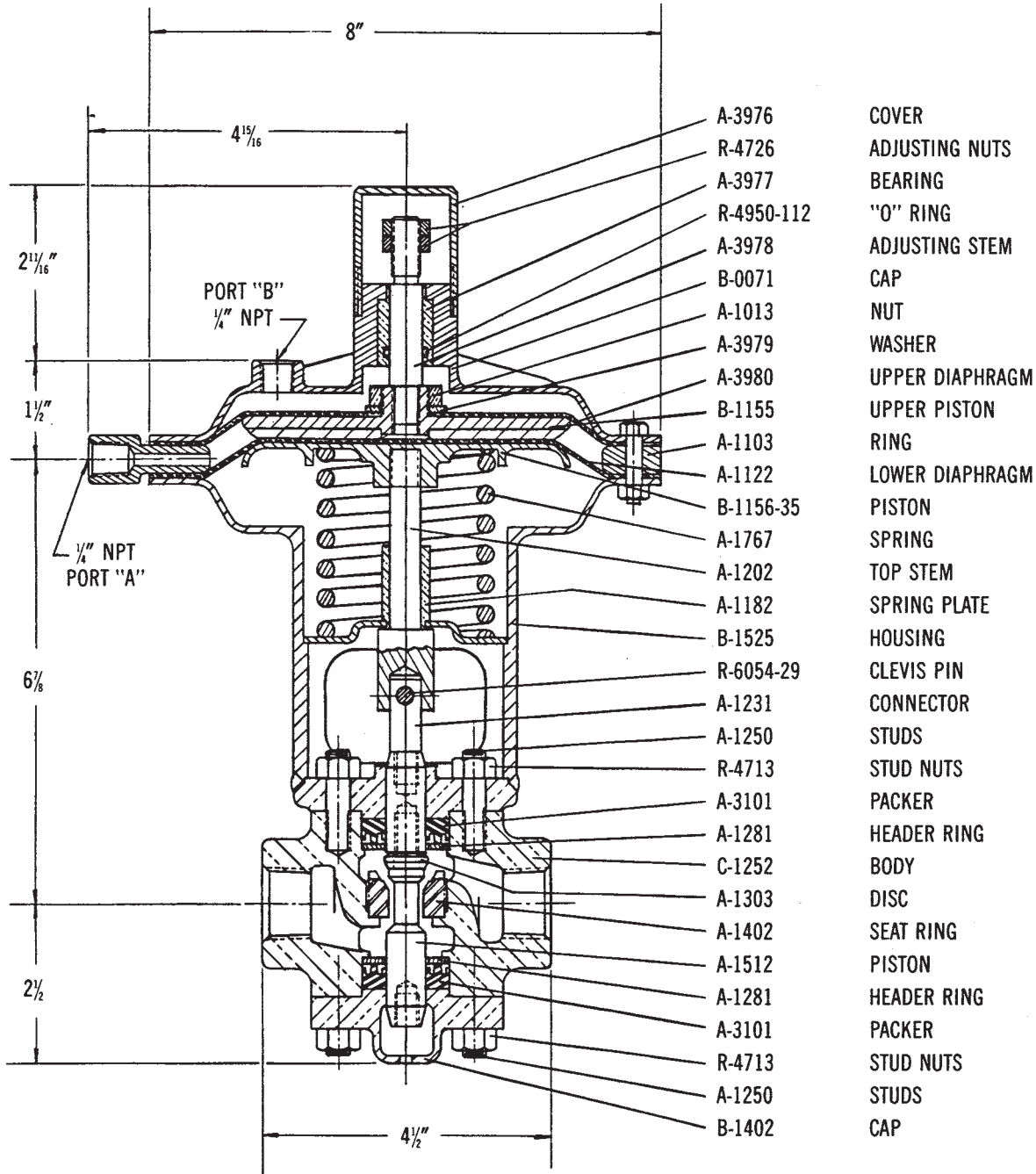

Specify Normally Open or Normally Closed

THE VALV-TROL CO., STOW, OHIO