

VALV-TROL TWO-PRESSURE VALVE ASSEMBLY

FOR WATER, 95/5 OR OIL SERVICE

35 PSI (2.4 Bar) air recommended on diaphragm



The **Valv-Trol Two-Pressure Operating "Valve"** is actually an assembly of three of our standard valves. This "valve" has proven to be an efficient and economical way to actuate a single acting hydraulic press or cylinder. The use of a low pressure fluid for most of the stroke conserves high pressure fluid which is more costly to generate. When the ram meets resistance near the end of its stroke, the higher pressure fluid can be applied automatically for final squeezing or clamping.

Each assembly is made up of a Balanced 3-Way Valve, an Angle Check Valve, and a High Pressure Inlet Valve. Our popular model B-0511 automatic inlet valve is standard with all sizes. It can be adjusted to open when ram pressure builds up to any point between 150 and 400 PSI (10 and 28 Bar). Optional automatic valves are shown on Bulletin A-7. Our model C-0008, **2-way Normally Closed Diaphragm Valve** is often used if separate control is more desirable than automatic operation.

Each valve is an independent unit.

Can be mounted in the most convenient position for simplified piping.

Maintenance is simplified.

Each valve can be fully serviced without removal from the line.

Model	Basic Size	Max. PSI *	Port Sizes			Construction *			
			Low Press.	High Press.	Cyl. & Drain	Cv	Body	Replaceable Trim	Seals
D-1050	3/4"	3500 (240 Bar)	1/2" or 3/4" NPT	3/4" NPT	3/4"	3.5 & 4.9	Bronze	Hardened S.S.	Buna N
D-1051	1"	3500 (240 Bar)	3/4" or 1" NPT	3/4" NPT	1"	9.0 & 13.0	Bronze	Hardened S.S.	Buna N
D-1052	1-1/4"	3500 (240 Bar)	1" or 1-1/4" NPT	3/4" NPT	1-1/4"	11.0 & 16.0	Bronze	Hardened S.S.	Buna N
D-1053	1-1/2"	3500 (240 Bar)	1-1/4" or 1-1/2" NPT	3/4" NPT	1-1/2"	19.2 & 30.0	Bronze	Hardened S.S.	Buna N
D-1054	2"	3500 (240 Bar)	1-1/2" or 2" NPT	3/4" NPT	2"	20.0 & 40.0	Bronze	Hardened S.S.	Buna N
D-1055	3"	3500 (240 Bar)	2-1/2" or 3" NPT	3/4" NPT	3"	54.6 & 83.5	Bronze	Hardened S.S.	Buna N
D-1056	4"	3500 (240 Bar)	3" or 4" NPT or Flanged	3/4" NPT	4"	88.0 & 140.0	Steel	Hardened S.S.	Buna N

*Consult factory for special requirements.

When ordering, specify model no., port sizes, your system pressures, and the H.P. inlet valve required.

The Valv-Trol Advantage

Many parts of Valv-Trol Valves are interchangeable between the same size 2-way, 3-way, and check valves. This helps you to reduce your spare parts inventory and allows us to maintain a more complete inventory for emergency availability and shorter lead times.

Our valves are all subjected to 100% pressure testing to ensure a drop tight seal before we ship to our customers.

THE VALV-TROL COMPANY • 1340 COMMERCE DRIVE • STOW, OHIO 44224
Phone: 800-497-2136 • Fax: (330) 686-2820 • E-mail: sales@valv-trol.com • www.valv-trol.com

© 2011 The Valv-Trol Company, all rights reserved

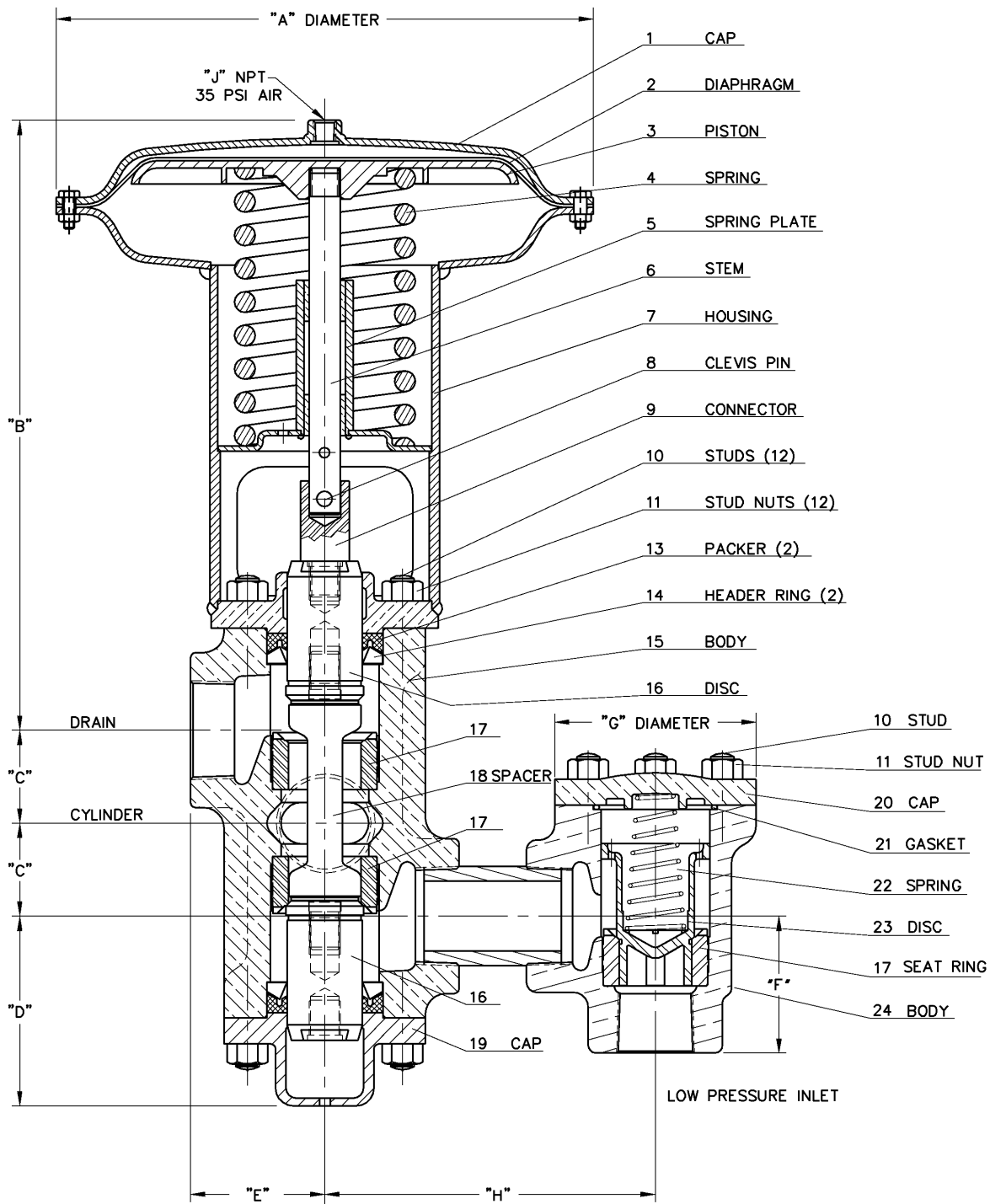

On 3" check valves, install cone spring with small end in the disc.

VALVE NUMBER	PIPE SIZE	A	B	C	D	E	F	G	H	J
D-1050	3/4"	8"	7-3/4"	1"	2-3/8"	2-1/8"	2-1/4"	3"	2-1/4"	1/4"
D-1051	1"	11"	13-1/4"	1-3/4"	4"	2-3/4"	2-1/2"	4"	2-1/2"	1/4"
D-1052	1-1/4"	11"	13-1/4"	1-3/4"	4"	2-3/4"	2-5/8"	4"	2-3/4"	1/4"
D-1053	1-1/2"	13"	14-7/8"	2-1/4"	4-5/8"	3-1/8"	3"	4-7/8"	3"	1/4"
D-1054	2"	13"	14-7/8"	2-1/4"	4-5/8"	3-1/4"	3-1/4"	4-7/8"	3-1/4"	1/4"
D-1055	3"	20"	21-1/2"	3-1/4"	6"	4-1/2"	4-3/4"	7"	4-3/4"	1/2"
D-1056	4"	20"	21-3/4"	4"	7-5/8"	8-3/8"	6-3/4"	9"	8-3/8"	1/2"

Illustration typical of 3/4"-3" valves. 4" 3-way ports, and check valve side port are furnished with weld neck companion flanges.

TWO-PRESSURE OPERATING VALVE

LOW 50-2000 PSI (3-138 Bar) HIGH TO 3,500 PSI (240 Bar)

PARTS LIST

Ref. No.	Valve No. Valve Size Valve Area	D-1050 3/4" .167 Sq. In.	D-1051 1 .398 Sq. In.	D-1052 1-1/4" .667 Sq. In.	D-1053 1-1/2" 1.081 Sq. In.	D-1054 2" 1.780 Sq. In.	D-1055 3" 4.233 Sq. In.	D-1056 4" 8.056 Sq. In.
1	Cap	B-1102	B-1104	B-1104	B-1106	B-1106	B-1108	B-1108
2	Diaphragm	A-1122	A-1124	A-1124	A-1126	A-1126	A-1128	A-1128
3	Piston	B-1156-35	B-1158-47	B-1158-47	B-1160-57	B-1160-57	B-1162-89	B-1162-89
4	Spring	A-1767	A-1160	A-1160	A-1168	A-1168	A-1178	A-1178
5	Spring Plate	A-1182	A-1184	A-1184	A-1186	A-1186	A-1188	A-1189
6	Stem	A-1202	A-1206	A-1206	A-1208	A-1208	A-1210	A-1210
7	Housing	B-1525	B-1544	B-1544	B-1562	B-1562	B-1582	B-1584
8	Clevis Pin	R-6054-29	R-6056-39	R-6056-39	R-6056-41	R-6056-41	R-6057-65	R-6057-65
9	Connector	A-1231	A-1236	A-1236	A-1238	A-1238	A-1240	A-1240
10	Studs	A-1250	A-1256	A-1256	A-1260	A-1260	A-1264	A-1268
11	Stud Nuts	R-4713	R-4715	R-4715	R-4716	R-4716	R-4718	R-4719
13	Packer	A-3101	A-3136	A-3136	A-3138	A-3138	A-3140	A-5271
14	Header Ring	A-1281	A-1286	A-1286	A-1290	A-1290	A-1293	- 0 -
15	Body—3-Way	D-1302	D-1304	D-1306	D-1308	D-1310	D-1312	D-1320
16	Disc—3-Way	A-1303	A-1306	A-1306	A-1310	A-1310	A-1312	A-1314
17	Seat Ring	A-1402	A-1406	A-1406	A-1410	A-1410	A-1412	A-1414
18	Spacer	A-1502	A-1506	A-1506	A-1510	A-1510	C-1150	C-1154
19	Cap—3-Way	B-1402	B-1406	B-1406	B-1410	B-1410	B-1412	B-1414
20	Cap—Check	A-1602	A-1606	A-1606	A-1610	A-1610	A-1612	A-1618
21	Gasket	R-4950-125	R-4950-227	R-4950-227	R-4950-232	R-4950-232	R-4950-243	R-4950-249
22	Spring	A-1720-A	A-1726-A	A-1726-A	A-1730-A	A-1730-A	A-1732-A	A-1734-A
23	Disc—Check	A-1320	C-1318	C-1318	C-1322	C-1322	C-1324	A-1395
24	Body—Check	B-1252	B-1254	B-1256	B-1258	B-1260	D-1314	D-1323
	Packer Cage	- 0 -	- 0 -	- 0 -	- 0 -	- 0 -	- 0 -	A-1295
	Cage O-Ring	- 0 -	- 0 -	- 0 -	- 0 -	- 0 -	- 0 -	R-4950-250
	Flange	- 0 -	- 0 -	- 0 -	- 0 -	- 0 -	- 0 -	A-3836
	Flange O-Ring	- 0 -	- 0 -	- 0 -	- 0 -	- 0 -	- 0 -	R-4950-238

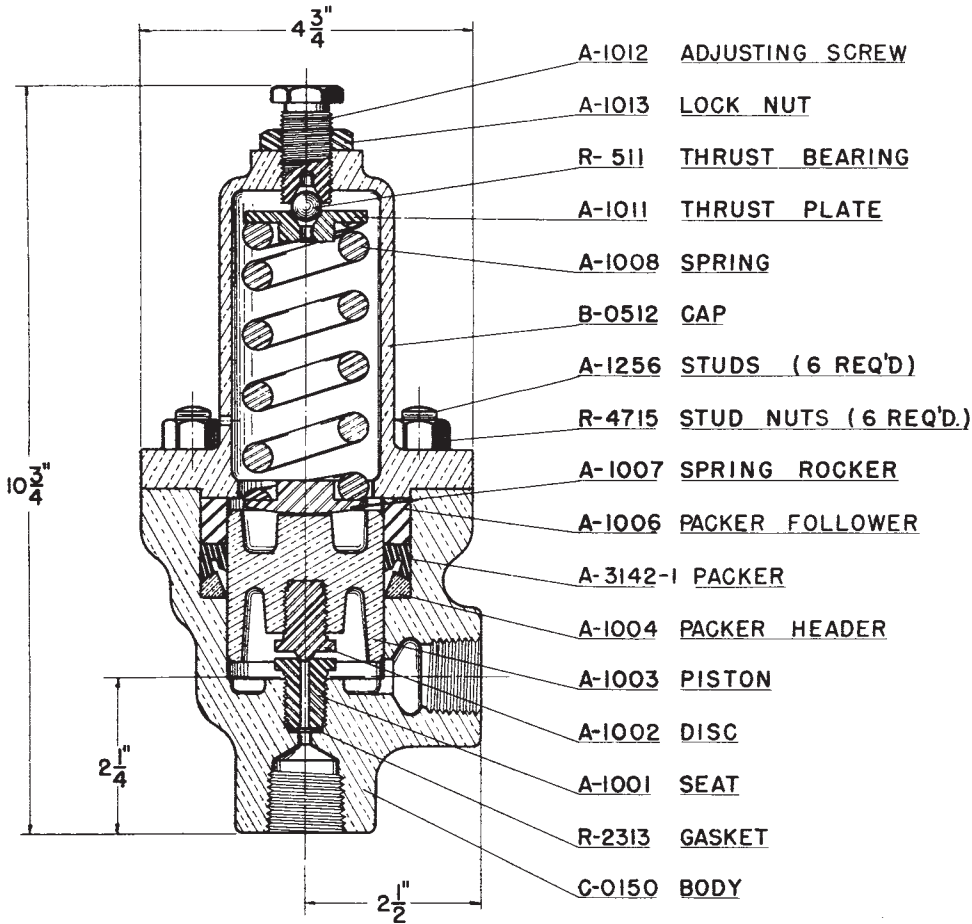

VT AUTOMATIC HIGH PRESSURE INLET VALVE NO. B-0511

PARTS DRAWING

FOR LOW PRESSURES
150 TO 400 PSI.
(10 to 28 Bar)
SEE BULLETIN A-7 FOR
MODELS WITH OTHER
LOW PRESSURE RATINGS

VT DIAPHRAGM CONTROLLED HIGH PRESSURE INLET VALVE NO. C-0008

PARTS DRAWING

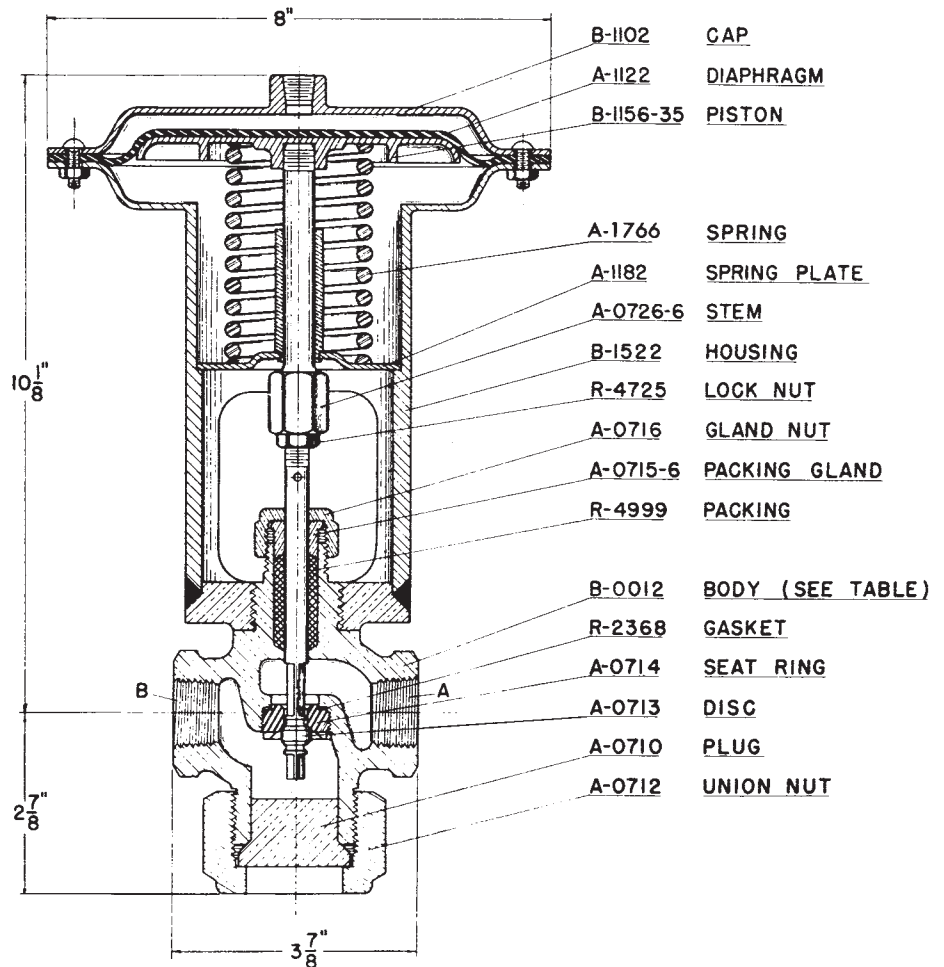

TWO TYPICAL HYDRAULIC PRESS CIRCUITS

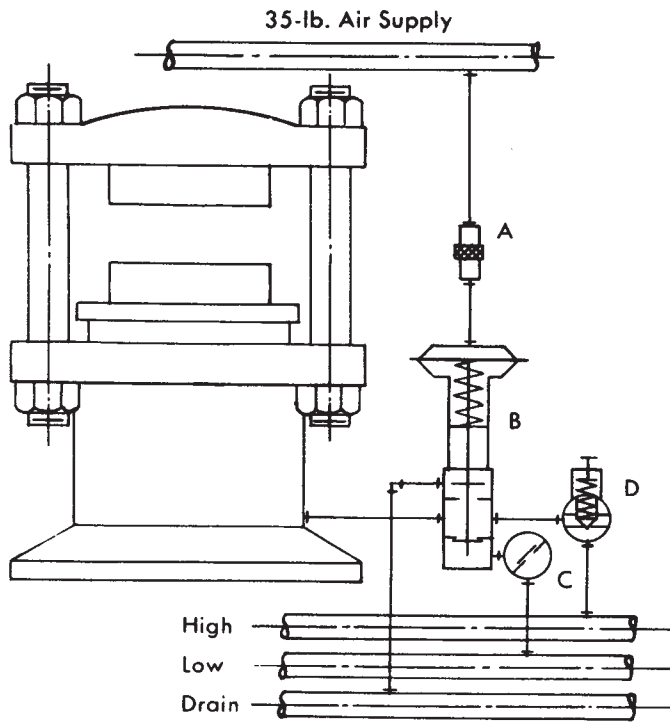

Figure I

- A—Manual Air Valve
- B—Balanced 3-Way Valve
- C—Angle Check Valve
- D—Automatic Inlet Valve

Figure 1 shows one of the simplest ways to control a press or cylinder with our valves. With this valve arrangement on a two-pressure hydraulic system, the cycle is started by applying air pressure to the diaphragm of valve "B". This can be done with a 3-way air valve that is manually or solenoid operated. Low pressure fluid can now enter the check valve "C" and the 3-way valve "B". When the ram or piston meets resistance at the end of its stroke, the pressure builds until the automatic high pressure inlet or sequence valve "D" opens the high pressure port. Now the ram has the maximum amount of squeeze. Valve "C" prevents loss of high pressure back into the low pressure system. The ram can be bumped as many times as required by shifting the air valve "A".

When the ram is ready to be retracted, the air supply is removed from valve "B" and the fluid is drained back to the reservoir. When the pressure to the ram has bled down to the setting of valve "D" the high pressure port closes.

Figure II shows a more complete way of controlling a hydraulic press. In addition to the basic opening and closing of the ram, it allows slow opening or closing of the press, stopping of the ram at any point in its stroke, delaying of high pressure kick-in, and operation of pullback and knock-out cylinders at the proper times. A pressure reducing valve (Bulletin A-31) is used to control the tonnage of the press. In this circuit, a Valv-Trol time cycle controller is used to completely control the sequence and timing functions of the solenoid valves.

There are many ways to valve and control a press. Let our years of experience help you meet your exact requirements.

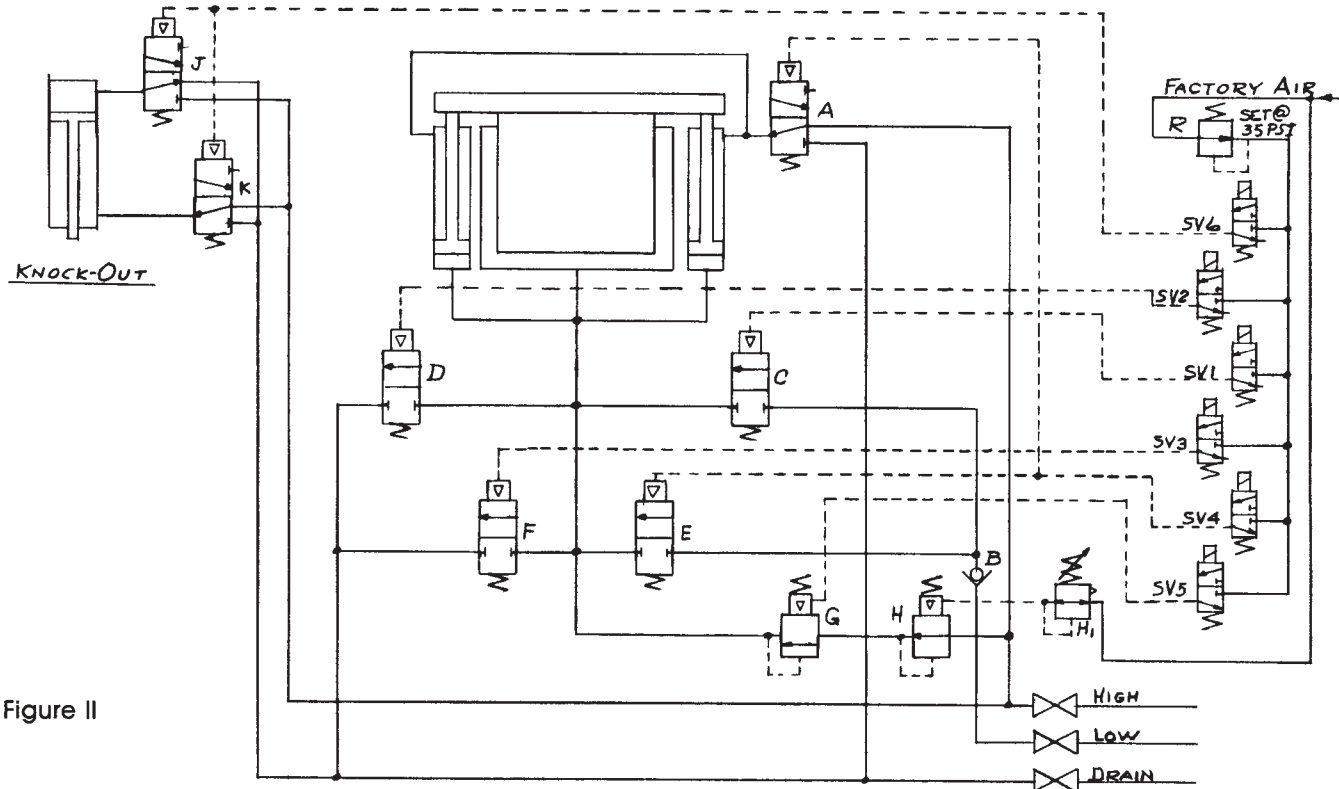

Figure II