

VALV-TROL PRESSURE REDUCING (REGULATING) VALVES

FOR WATER, 95/5, OIL OR OTHER LIQUIDS



The Valv-Trol Pressure Reducing Valve is used to regulate or reduce primary hydraulic pressure for presses and cylinders for tonnage control. It comes complete with a Precision Air Regulator and Air Gauge.

Adjustment of hydraulic pressure is made by changing the air pressure on the diaphragm top. The graph below shows the relationship of air to hydraulic pressure.



Seat, disc, and piston assembly made of hardened stainless steel.

Proven to be very resistant to the effects of corrosion, wear, and wire drawing for longer service life.

Seating surface is separate from throttling surface.

Even with accumulated wear on throttling surface, valve will shut off tightly. No need to provide constant bleed of fluid on secondary side.

Model	Port Size	Max. Pressure Rating	Secondary Pressure Range	Net Area	Construction		
					Body	Trim	Seals
D-1234	3/4" or 1" NPT	4000 PSI (275 Bar)	500 PSI to 3500 PSI (34 Bar to 241 Bar)	.058 Sq. In.	Bronze	Hardened S.S.	UHMWPE
D-1234-A	1" NPT	4500 PSI (345 Bar)	500 PSI to 3500 PSI (34 Bar to 310 Bar)	.107 Sq. In.	Steel	Hardened S.S.	Polyurethane

Consult factory for special requirements.

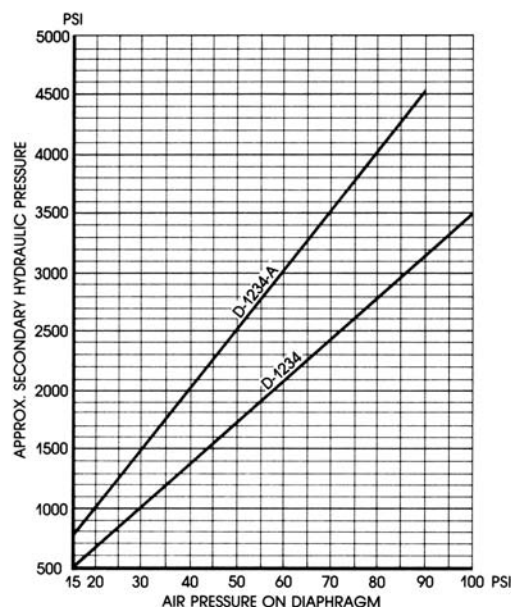

Our valves are all subjected to 100% pressure testing to ensure a drop tight seal before we ship to our customers.

THE VALV-TROL COMPANY • 1340 COMMERCE DRIVE • STOW, OHIO 44224
 Phone: 800-497-2136 • Fax: (330) 686-2820 • E-mail: sales@valv-trol.com • www.valv-trol.com

MODEL D-1234 PRESSURE REDUCING VALVE

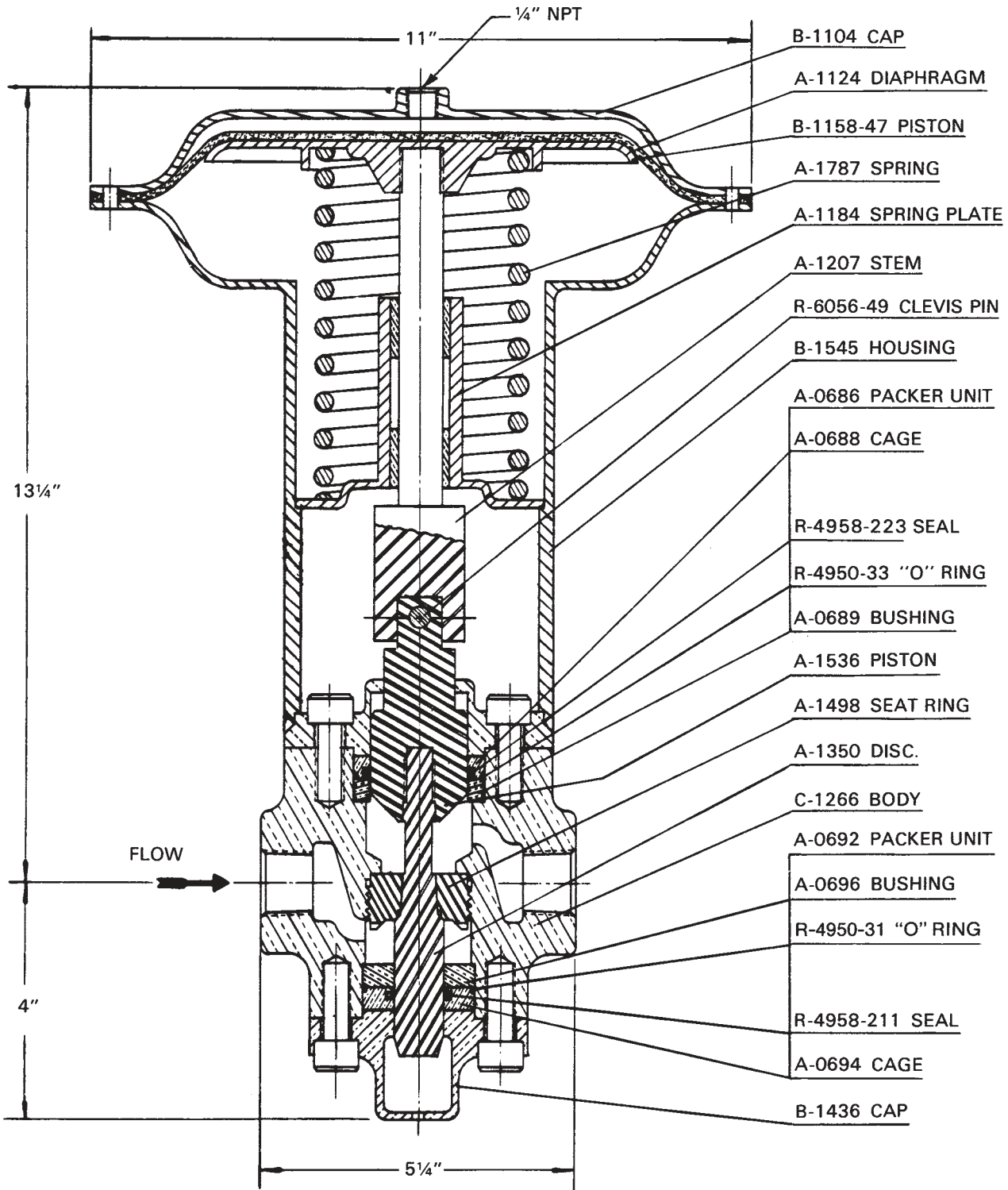

The disc, piston, and seat ring are available only as a matched 3-piece assembly.

THE VALV-TROL CO., STOW, OHIO